



WARNING

Looped cords, looped bead chains or other flexible looped devices may cause a strangulation hazard for children under 5 years. **KEEP CORDS AND CHAINS OUT OF REACH OF CHILDREN**



Roller Blind Installation Instructions

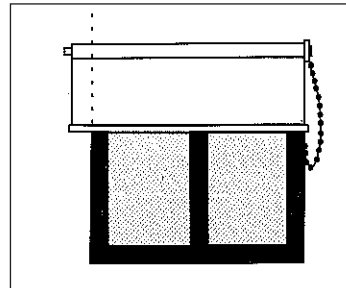
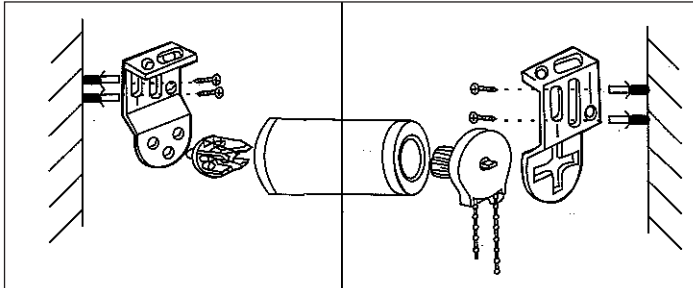

1. Unroll the blind onto a flat surface.
2. Measure the width of the fabric that will be required.

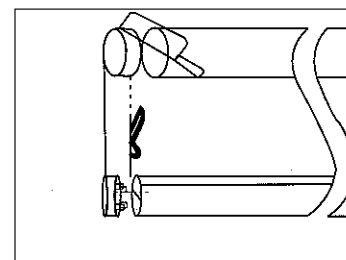
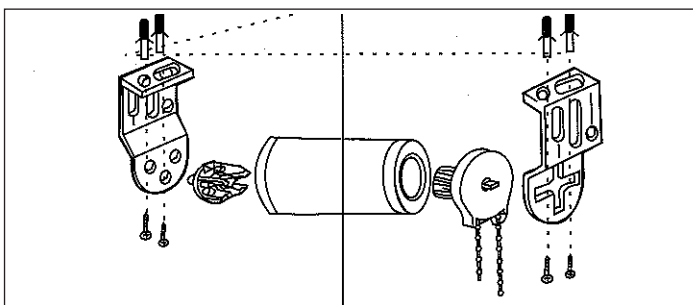

3. Cut off the excess fabric using scissors or a sharp cutting knife. A straight edge cut is important.

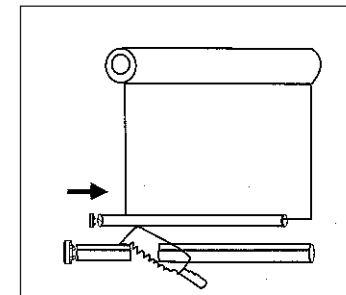
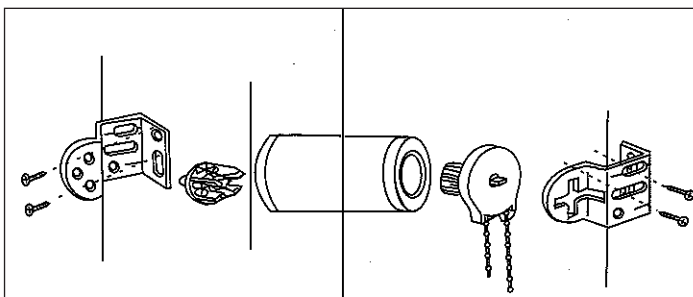

4. Using a small hacksaw, cut the top roller tube 0.15cm wider than the fabric.

5. Using a small hacksaw, cut the bottom roller tube.
6. Now you can re-roll your roller blind, ensuring the pattern is on the outside.

7. Now you can install your blind.

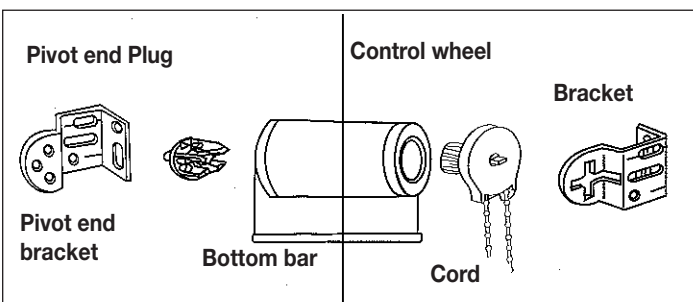

WARNING

Warning. Looped cords, looped bead chains or other flexible looped devices can cause strangulation. Hazardous for children under 5 years of age. Keep cords and chains out of reach of children. Any exposed looped cord, looped bead chain or other flexible looped devices must be attached no less than 1.6 meters from the floor.



WARNING

Young children can strangle in the loop of pull cords, chain and bead cords that run through window coverings. They can also wrap cords around their necks.

To avoid strangulation and entanglement, keep cords out of reach of young children.

Also,

All blinds with chain cord

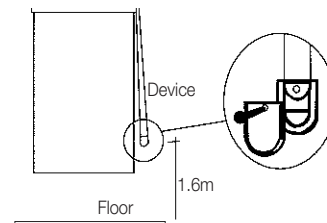

Device must be attached 1.6 meters from floor

1. Install safert devices that remove the cord loop or reduce access to cords.
2. Move cots and furniture away from window covering cords.

INSTALLING YOUR BLIND

1. Fit the bracket to the side of your window where the control cord is to hang. Fit the pivot end to the other side.

2. Fit the control wheel and the pivot end into the roller.

3. Fit the pivot end into the bracket. Your roller blind will now operate by pulling the cord.

3. Fit the pivot end into the bracket. Your roller blind will now operate by pulling the cord.